

Instruction manual for rotary vane pump - VP serie



INSTALLATION

The pump must be installed by specialist staff with adequate equipment.

WARNINGS

For foodstuff applications allow water to circulate at a temperature of 60°C inside the Pump for at least 10 minutes to disinfect; do NOT use used water for disinfection. This product and the internal components were not designed to pump "hazardous" fluids (e.g. toxic and/or flammable).

Ensure the data on label of the model is consistent with the usage.

In case of continuous operation, ensure the pump is installed in a sufficiently ventilated space to allow dissipation of heat generated by operation of the motor. The pump must be assembled horizontally.

To avoid noise and vibrations of the mechanical parts, we advise to assemble the motor on rubber shock absorbers. For usage of fluids other than water, contact Gotec technical support.

ASSEMBLY

Motor with clamp coupling:

- › Do not remove the two plastic plugs located in the suction and discharge holes of the pump before assembling the fittings and tube, in order to avoid entry of dirt that could damage the internal components the pump.
- › Ensure the motor is disconnected from the electrical power supply.
- › Place clamping (E) on the pump on the fastening ring (A).
- › Fix the pump to the motor inserting the shaft (C) into the motor shaft (D).
- › Push it in until the ring of pump (A) is in contact and well aligned with the motor ring (B).

- › Turn the Pump to the desired position.
- › Place clamp (E) to overlap the fastening rings (A+B).
- › Tighten the screw of the clamping (E) using a max torque of 2.5-3 Nm.
- › Ensure the screw of the clamp is tight enough, to prevent rotation of the pump by the motor.
- › If the pump is noisy when switched on, the screw of the clamp must be loosened, re-place the pump and tighten the screw again.
- › Run the pump multiple times until the air inside is eliminated.

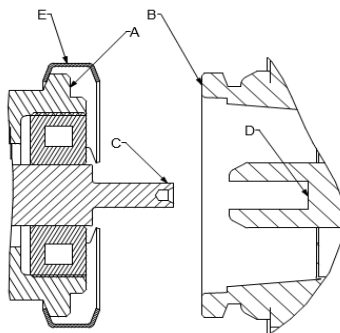

PUMP CONNECTION TO CIRCUIT

Ensure the circuit is correctly cleaned before connecting into the pump. Appropriate diameter pipes and fittings must be installed on the pump suction line.

Following instructions:

Tubes $\geq \varnothing 8$ mm	For VP150
Tubes $\geq \varnothing 12$ mm	For VP400

For GAS connection, the tightness is guaranteed by using fittings with an O-ring, PTFE tape wrapped around the male thread or ogive tube.

For NPT connection, the seal is guaranteed by contact between the threading, PTFE strip wrapped on the male thread or using an ogive tube.

Sealant is not recommended on the tubes.

Hold the pump in your hand by the part opposite the couplings and tighten the joints with a torque not exceeding 20 Nm to avoid damaging the threads on the pump threads.

When tightening the coupling, do not use the motor as a support for the pump to avoid misalignment and stress on the shafts of the pump and motor.

ELECTRICAL CONNECTION

- › The electrical power supply must comply with the electrical data indicated on the motor, paying particular attention to the voltage and frequency. The motor must not be connected to the electrical mains during installation.
- › Rotation of the motor is clockwise. Otherwise, if it is

operated counter-clockwise, the pump will not work.
› Ensure the motor is equipped with a thermal protection to avoid overheating caused by faults or critical operating conditions.

OPERATION CONDITIONS

- › For special applications, please contact Gotec sales team.
- › A hydraulic circuit with curves and sudden changes in the diameter of the tube causes turbulence in the water and resonance in the machine.
- › Take a note that final validation of the pump is the client's responsibility as performance and reliability could be affected by operating conditions and/or hydraulic circuits.
- › Maximum working pressure must not exceed 16 bar.
- › For further technical information on limits and operation conditions refer the technical data sheets of the product.

CORRECT USAGE

The pump was designed to work only with clean fluids without solid particles. For this reason, it is necessary to install, before the pump, a filter of 10 μ m with a filtering area large enough not to cause flow and pressure losses in the circuit. In case of using a filter, clean it regularly. A dirty filter that reduces the flow rate will cause cavitation and rapid wear of the pump. Rotary vane pumps are self-priming, but dry running can cause overheating and failure of the mechanical seal and internal components, resulting in malfunctions. Pay particular attention and implement the necessary countermeasure to avoid hazardous or harmful conditions.

It is therefore essential to ensure that water entry is open before operating the pump.

We suggest pouring a little water into the pump before operating it to keep the sealing area wet during the first few seconds of operation.

If the water supply is subject to low pressure or low flow, it is necessary to install a low-pressure switch in front of the pump to be able to stop the motor in case of lack of water.

To avoid cavitation, if the tank is at atmospheric pressure, do not install the pump more than 1 m above the maximum liquid level in the tank. The maximum priming capacity is 1 m.

The pump is equipped with a by-pass. The bypass valve is a safety valve that serves to ensure the system in which the pump is installed does not exceed the required pressures and must not be used as a pressure regulator. If it is used in this way, the excess water will recirculate back into the pump heating and promoting scale build-up on the pump components. The maximum differential pressure should be at least 3 bar lower than the set value of the bypass valve to avoid operation with the valve open. In any case, the maximum differential pressure must not exceed 16 bar.

If the adjusting screw of the bypass valve is tampered with, the original setting will no longer be guaranteed. In case of doubt or clarification, contact Gotec technical support.

WARRANTY CONDITIONS

This warranty is limited to repair or replacement of the faulty product at the exclusive discretion of Gotec, returned at the client's expense, provided that the analysis shows that the part(s) in question was indeed defective at the time of sale.

The warranty is not valid if:

- › The installation and use instructions were ignored.
- › The pump was disassembled by non-Gotec technician or repaired with non-original parts.
- › The pump worked without water or in cavitation.
- › Solid particles were found in the Pump.
- › The pump was used for applications or working conditions incompatible with the pump or for applications non-compliant with the specifications agreed with Gotec.
- › For pumps with bypass valves, when the differential pressure is under 3 bar or over 16 bar.

Repair or replacement of faulty parts during the period covered by warranty does not extend the original period of warranty.

The purchaser/user is responsible for suitable disposal or recycling of the product when no longer in use or at the end of its useful life.

For further information, consult the sales conditions.

CERTIFICATION

The product complies with the directives:

- › NSF standard 169 (except joints in FKM).
- › M.D. 174/04 of the Ministry of Health, on materials and objects that can be used in fixed systems for collection, treatment, supply and distribution of water intended for human consumption.
- › EC Regulation no.1935/2004 relating to materials and objects intended to come in contact with foodstuff products.
- › EC Regulation no.2023/2006 relating to good practices for the manufacture of materials and objects intended to come in contact with foodstuff products.

The units with a motor also meet the following requirements:

Directive 2011/65/EU of the European Parliament, on the restriction of the use of certain hazardous substances in electronic and electrical equipment) – RoHS

Gotec SA

Route de Mangold 11 • CH-1958 St-Léonard • Switzerland
Tel. +41 27 205 72 05 • www.gotec.ch • info@gotec.ch